

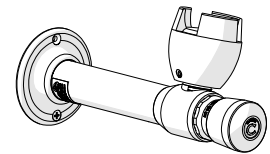

Ezy-Drink[®] Lead Safe[™] Horizontal Push Button Drinking Bubbler Tap

PRODUCT CODES:

- 170.50.13.01



SPECIFICATIONS

- Drinking taps are designed to operate at full mains pressure.
- Rubber mouthguard is designed to help protect teeth when drinking.
- Rubber mouthguard is resistant to fungal and bacterial attack and has a high resistance to sunlight.
- Adjustable built-in flow restrictor.

IMPORTANT: All Ezy-Drink[®] push button drinking taps are tested in accordance with AS/NZS 3718 and leave our premises in good working order.

TECHNICAL DATA

Inlet	1/2" BSP - Female	
Outlet	Rubber mouthguard	
Headwork	Push button	
Working Pressure Range (kPa)	Min	50
	Max	500
Working Temperature Range (°C)	Min	5
	Max	60
Nominal Flow Rate (LPM)	2	
Finish	Chrome	

NOTE: Galvin Specialised continually strive to improve their products. Specifications may change without notice.

TOOLS REQUIRED

- Power drill
- Spanner or adjustable crescent
- Screw driver





Product Installation Guideline

Version 1, 4 February 2020, Page 2 of 4

PRE-INSTALLATION - MOUNTING DETAILS

- If the mounting holes do not already exist, mark out and drill the holes in the wall/sheet, as shown in rough-in dimensions.

Note: Before installation, all lines must be flushed. We recommend that a line strainer be installed prior to drinking taps to eliminate any foreign material.

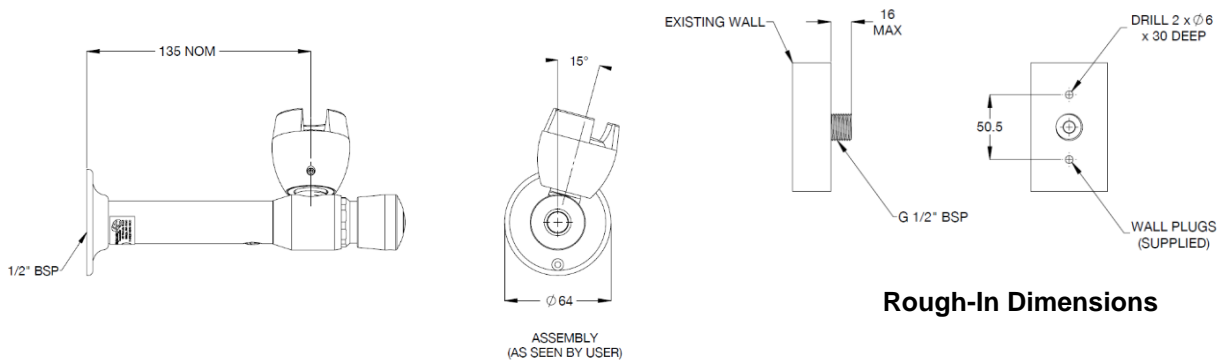

Rough-In Dimensions

INSTALLATION

IMPORTANT: Galvin Specialised products must be installed in accordance with these installation instructions and in accordance with AS/NZS 3500, the PCA and your local regulatory requirements. Water and/or electrical supply conditions must also comply to the applicable national and/or state standards. Failing to comply with these provisions shall void the product warranty and may affect the performance of the product.

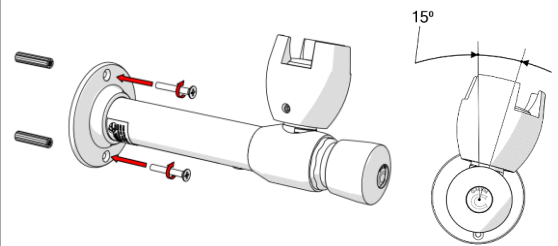
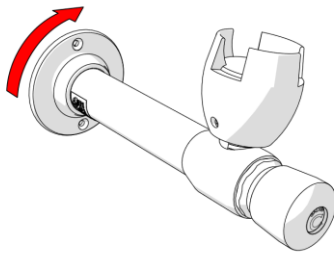

1. Fit tap assembly

- Fit wall plugs to wall as per the rough-in dimensions.
- When applying thread tape or sealant to the inlet, ensure the opening is not obscured. Failure to do so may restrict or block the flow restrictor, affecting the flow of water.
- Screw tap onto existing spud until the flange is touching the wall.
- Ensure the mouthguard is in the correct position and the holes in the flange align with the wall plugs.

2. Secure the body

- Secure the body with supplied screws.



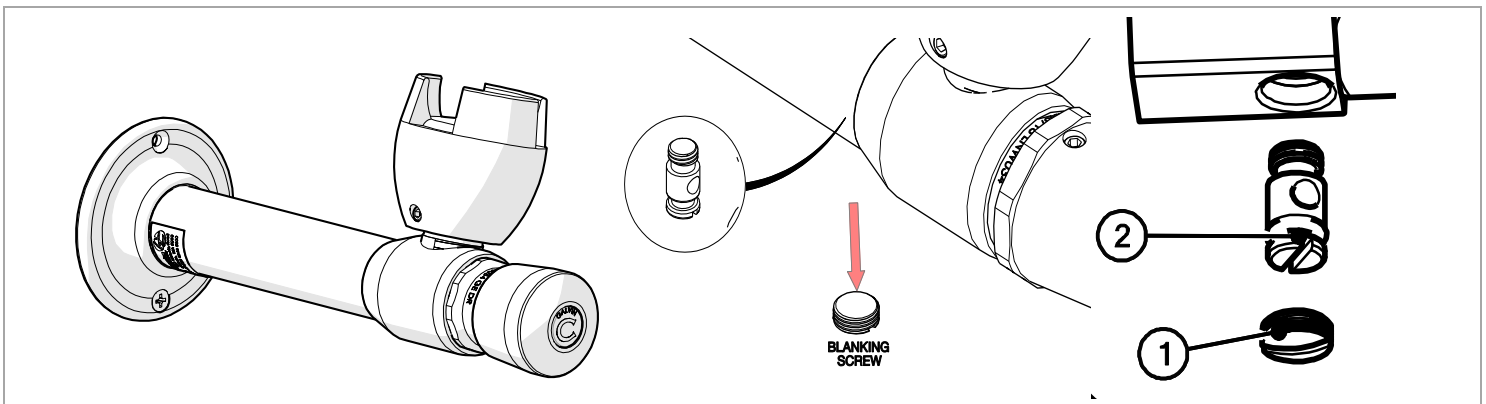

3. Testing

- Once the drinking tap has been installed and tested for leaks, the water height may be adjusted to suit the available pressure.
- To adjust water flow
 1. Remove the blanking screw ①
 2. Adjust the water height by turning the regulator screw ②
 3. Replace blanking screw

Note: The full range from minimum flow to maximum flow is only ¼ turn

TROUBLESHOOTING

PROBLEM	CAUSE	RECTIFICATION
Inconsistent flow	Blocked top assembly or regulating screw	Remove top assembly and/or regulating screw and clean
Water is not flowing from tap	Water is turned off	Turn on water
	Blocked regulating screw	Remove regulating screw and clean
Continuous flow	Top assembly loose or internally obstructed or damaged	Remove top assembly, clean with water and re-grease spindle if required
Rate of flow inadequate	The flow regulator screw may not be adjusted correctly	Remove blanking screw and adjust flow regulating screw as described
Button hard to press	The mains pressure may be too great	Reduce to below 500kPa (70PSI) Regrease spindle if required



WARRANTY

The warranty set forth herein is given expressly and is the only warranty given by the Galvin Engineering Pty Ltd. With respect to the product, Galvin Engineering Pty Ltd makes no other warranties, express or implied. Galvin Engineering Pty. Ltd. hereby specifically disclaims all other warranties, express or implied, including but not limited to the implied warranties of merchantability and fitness for a particular purpose.

Galvin Engineering Pty Ltd products are covered under our manufacturer's warranty available for download from www.galvinengineering.com.au Galvin Engineering Pty Ltd expressly warrants that the product is free from operational defects in workmanship and materials for the warranty period as shown on the schedule in the manufacturer's warranty. During the warranty period, Galvin Engineering will replace or repair any defective products manufactured by Galvin Engineering without charge, so long as the terms of the Manufacturer's warranty are complied with.

The remedy described in the first paragraph of this warranty shall constitute the sole and exclusive remedy for breach of warranty, and Galvin Engineering Pty Ltd shall not be responsible for any incidental, special or consequential damages, including without limitation, lost profits or the cost of repairing or replacing other property which is damaged if this product does not work properly, other costs resulting from labour charges, delays, vandalism, negligence, fouling caused by foreign material, damage from adverse water conditions, chemical, electrical or any other circumstances over which Galvin Engineering has no control. This warranty shall be invalidated by any abuse, misuse, misapplication, improper installation or improper maintenance or alteration of the product.

